

OWNER MANUAL

 **ADVENTURER**

 **Adventurer**
Manufacturing

TABLE OF CONTENTS

OWNER MANUAL	1
INTRODUCTION	1
<i>INFORMATION IN THIS MANUAL</i>	1
<i>DEALER'S RESPONSIBILITY</i>	1
SAFETY AND PRECAUTIONS	2
<i>SAFETY KEY</i>	2
<i>SAFETY MESSAGES</i>	2
PROLONGED OCCUPANCY	4
LIMITED WARRANTY	4
<i>IMPORTANT INFORMATION ABOUT YOUR WARRANTY</i>	4
<i>ANNUAL INSPECTIONS AND ANY REQUIRED SERVICE</i>	4
<i>EXCLUSIONS</i>	5
IDENTIFICATION	5
CENTER OF GRAVITY "COG"	6
<i>WEIGHT INFORMATION</i>	7
PROPANE SYSTEMS	7
<i>LP GAS SAFETY PRECAUTIONS</i>	8
<i>FILLING LP GAS TANKS</i>	8
<i>LIGHTING LP GAS APPLIANCES</i>	8
<i>USING LP GAS SYSTEMS AT LOW TEMPERATURES</i>	9
FIRE AND SAFETY	9
<i>LPG LEAK DETECTOR</i>	9
<i>COMBINATION SMOKE & CARBON MONOXIDE DETECTOR</i>	10
<i>FIRE EXTINGUISHER</i>	10
ELECTRICAL SYSTEM	11
<i>ELECTRICAL CONNECTION TO TRUCK</i>	11
<i>GROUND FAULT INTERRUPTER</i>	11
<i>SYSTEMS MONITOR PANEL</i>	12
<i>WATER PUMP CONTROL SWITCH</i>	12
<i>MONITOR PANEL-LEVELS INDICATORS SWITCH</i>	12
WATER SYSTEM	12
<i>FRESH WATER TANK</i>	12
<i>CITY WATER HOOKUP</i>	13
<i>HOT WATER TANK</i>	13
WASTEWATER SYSTEM	13
LOADING & UNLOADING YOUR CAMPER	14
<i>DUALY BRACKETS</i>	15

<i>MANUAL JACK OPERATING INSTRUCTIONS</i>	15
<i>OPERATING REMOTE CONTROL ELECTRIC JACKS</i>	15
<i>ELECTRIC JACK OPERATING INSTRUCTIONS</i>	16
<i>CONTINUATION FOR ALL JACK VERSIONS</i>	16
<i>UNLOADING</i>	17
TOWING AND HITCH SYSTEMS	17
LOADING CARGO	17
<i>CARRYING CAPACITY</i>	17
CAMPER FEATURES	18
<i>VENTS</i>	18
<i>LIGHTING</i>	18
<i>BATHROOM</i>	18
<i>DINETTE BED</i>	18
<i>LADDER AND ROOF RACK</i>	18
<i>EMERGENCY ESCAPE</i>	19
<i>STORAGE</i>	19
APPLIANCES	19
<i>LIGHTING LP GAS APPLIANCES</i>	19
<i>MICROWAVE OVEN</i>	19
<i>REFRIGERATOR</i>	19
<i>WATER HEATER</i>	20
<i>RANGE / OVEN</i>	20
SLIDE OUT	20
<i>OPERATING THE ELECTRIC SLIDE OUT</i>	20
<i>SLIDE-OUT MANUAL OPERATION</i>	21
MAINTENANCE	21
<i>MAINTAINING EXTERIOR AND INTERIOR FINISHES</i>	21
<i>EXTERIOR</i>	22
<i>INTERIOR</i>	22
<i>DRAPES AND UPHOLSTERY</i>	22
<i>FLOORS AND CARPETING</i>	22
<i>POWER RANGE HOOD</i>	22
<i>REFRIGERATOR</i>	22
<i>SHOWER CARE</i>	23
<i>DRAINS</i>	23
WINTERIZATION	23
<i>WINTERIZING YOUR CAMPER</i>	23
<i>FRESH WATER SYSTEM</i>	23

<i>WASTEWATER SYSTEM</i>	<u>25</u>
PREPARING YOUR UNIT FOR STORAGE	<u>25</u>
<i>SHORT-TERM STORAGE ABOVE FREEZING (LESS THAN 60 DAYS)</i>	<u>25</u>
<i>LONG-TERM STORAGE ABOVE FREEZING</i>	<u>25</u>
<i>GENERAL CAMPER WINTER STORAGE CHECKLIST</i>	<u>26</u>
<i>REACTIVATING THE UNIT AFTER STORAGE</i>	<u>26</u>
TRAVEL TIPS	<u>27</u>
<i>SOME USEFUL EQUIPMENT TO TAKE ALONG</i>	<u>28</u>
TROUBLESHOOTING	<u>28</u>
<i>FAQ</i>	<u>28</u>
NOTES	<u>30</u>
NOTES	<u>31</u>
NOTES	<u>32</u>
ADVENTURER MANUFACTURING INFORMATION	<u>33</u>

INTRODUCTION

ADVENTURER LIMITED PARTNERSHIP (Adventurer Manufacturing Inc.) as further noted in this manual, would like to take this opportunity to thank you for choosing one of our truck campers. We have sought to anticipate your needs and desires with respect to convenience, style, safety, and engineering. Customer satisfaction and goodwill are of primary importance, so we have provided this manual to assist you in understanding the proper use, operation, and maintenance of the various components and systems that have been designed into your truck camper.

Study this manual carefully, as well as the manuals included from the manufacturers for the appliances and equipment installed in your unit. Your dealer should take you through the unit and explain how each of the systems is operated, making sure you understand it fully before you set out on the road.

Product improvement is a continuing process at Adventurer Manufacturing; thus, we reserve the right to change materials, components, and specifications without prior notice.

In the interest of safety, your recreational vehicle has been designed and constructed to meet or exceed the requirements of applicable Recreational Vehicle Industry Association & ANSI codes.

Adventurer Manufacturing warranty can be registered at amlrv.com / adventurercampers.com Please complete the on-line registration within 15 days of purchase in order to validate the warranty.

Should you have additional questions or problems regarding operation, maintenance, service or warranty, please contact your dealer for assistance.

This manual has been designed to cover our complete line of Adventurer Truck Campers.

INFORMATION IN THIS MANUAL

Products and components in Adventurer Manufacturing manufactured products may change without notice. This manual is intended to be a guide only. Please refer to the individual component instructions and warranties found in your Owner Supplement Bag.

DEALER'S RESPONSIBILITY

Adventurer Manufacturing delivers the best quality in our campers to the dealer. Before shipping, every camper has been inspected to ensure it is complete and of the best quality. As with any owner, the dealer must also inspect and reseal units annually as necessary as they await sale.



The dealer will perform a complete inspection of the unit to see that it is free from defects. Your dealer at the time of purchase should walk you through the camper and explain the proper usage of the following.

- Appliances
- RV Hookups
- Electrical Systems
- Plumbing Systems
- Loading and Unloading
- Seals

SAFETY AND PRECAUTIONS







NOTICE: We have placed many important safety messages in your camper and throughout this manual. Please read and follow them carefully to avoid property damage injury or death.















SAFETY KEY

 DANGER	Indicates a hazardous situation that, if not avoided, will result in death or serious injury.
 WARNING	Indicates a hazardous situation that, if not avoided, could result in death or serious injury.
 CAUTION	Indicates a hazardous situation that, if not avoided, could result in minor or moderate injury.

NOTICE: Indicates information considered important, but not hazard-related (e.g. messages relating to property damage).

SAFETY MESSAGES

 WARNING	Failure to follow COG loading instructions may change the handling of truck, causing accident, injury and death.
 WARNING	Overloading may cause accident, injury or death.
 WARNING	It is your responsibility to ensure weight capacity is not exceeded. Accident, property damage, injury or death may occur.
 DANGER	LP gas is flammable and potentially explosive. Always follow proper handling, lighting and ventilation procedures.
 DANGER	The distinctive ODOR of LP gas indicates a leak.
 DANGER	<p style="text-align: center;">IF YOU SMELL GAS:</p> <ol style="list-style-type: none"> 1. Extinguish all open flames, pilot lights, lanterns and smoking materials. 2. DO NOT touch electrical switches. 3. Shut off the gas supply at the tank valve(s) or gas supply connection. 4. Open the windows and exit the unit leaving the door open. 5. Stay out of the unit until the odor clears. 6. Have the propane system checked IMMEDIATELY and the cause of the leak corrected BEFORE using the system again.
 WARNING	Do NOT fill propane containers to more than 80% of capacity. Overfilling can result in uncontrolled gas flow which can cause FIRE and EXPLOSION. A properly filled container holds about 80% of its volume as liquid.

 WARNING	Turn off LP main valve and individually turn off gas appliances or electrically disconnect automatic ignition appliances before entering an LP gas bulk plant or motor fuel service station.
 DANGER	NEVER ignore any ALARM. Failure to respond can result in injury or death.
 WARNING	This propane detector detects the presence of LP gas, it does NOT disconnect the gas supply. The camper interior electrical harness must be connected to a power source for proper operation.
 WARNING	Test the operation of this alarm after the recreation vehicle has been in storage, before each trip and at least once per week during use.
 WARNING	The test button only tests the alarm circuit, not the sensor. You should use propane or butane gas to test the sensor. Replace the alarm after 5 years.
 WARNING	This smoke/CO alarm can not operate without working batteries. Removing the batteries for any reason, or failing to replace the batteries at the end of their service life, removes your protection.
 CAUTION	When unloading your camper, be sure all tie-downs and electrical connections are disconnected.
 WARNING	Use extreme caution when unloading your camper in a strong wind. Load and unload your camper on level ground, NEVER an obvious grade.
 DANGER	Keep children and animals away from the area when raising or lowering the camper. Avoid putting any part of your body under the camper during the procedure.
 WARNING	Cooking appliances require fresh air for safe operation.
 WARNING	It is not safe to use cooking appliances for comfort heating. Do NOT use open flames to warm the living area.
 WARNING	Do Not install fuses with amperage ratings greater than specified, as this may cause a fire.
 WARNING	Towing will change the handling and braking characteristics of your truck and camper.
 WARNING	Do Not use automotive or windshield washer antifreeze in the camper water system. These could be harmful if swallowed.

⚠ WARNING Use extreme caution when using the ladder and accessing the roof of your camper. Fall, serious injury or death may occur.

PROLONGED OCCUPANCY

Your Adventurer Truck Camper has not been designed for permanent housing or lodging. Using your camper in this manner may lead to deterioration of the structure, interior finishes, fabrics, carpeting and window coverings. Property damage due to long term use may not be considered normal use and may under the terms of the warranty constitute misuse, abuse or neglect, and may reduce your warranty protection.

LIMITED WARRANTY

Adventurer Manufacturing hereby warrants each truck camper manufactured to be free from defects in material and workmanship under normal service and use. The manufacturer's obligation under this warranty shall be limited to repairing or replacing any part or parts therein deemed to be defective upon manufacturer's examination for one year from original retail purchase from an authorized Adventurer Dealer. Also provided is a **three year limited structural warranty**, which shall become effective only if the warranty registration is properly filled out and completed on-line at adventurercampers.com. This warranty shall not apply where the product is being used for rental, commercial and/or leasing purposes or has been subject to damage caused by misuse, accident, alternation or negligence. This warranty does not cover refrigerators, stoves, water heaters, furnaces or any other components, which are protected by their respective manufacturer's warranties. Also, there will be no reimbursement for transportation, gas, food or lodging.

IMPORTANT INFORMATION ABOUT YOUR WARRANTY

At Adventurer Manufacturing, we would like to ensure that you enjoy many years of trouble free relaxation in your new Adventurer Truck Camper. We ask that you read the terms and conditions of your warranty thoroughly for full comprehension of what must be met for the warranty to remain valid. In order for the warranty to become effective, the warranty must be registered on-line at adventurercampers.com **no later than 15 days from date of purchase from the dealer**. This should be done by the dealer upon delivery, but you need to confirm that this has been completed to activate your warranty.

Normal maintenance (refer to the maintenance section of this manual) is the responsibility of the owner. To keep the structural warranty in force, owners are required, at their own expense, to bring their truck camper to their authorized dealer for annual inspections. **Failure to provide routine maintenance may void this warranty.**

ANNUAL INSPECTIONS AND ANY REQUIRED SERVICE

The following will be inspected:

- Inspect under floor protection for damage, punctures and a moisture tight seal.
- Inspect all entry doors, baggage doors, access doors, windows, taillights, clearance

lights, marker lights, moldings, and attachments for a moisture tight seal.

- Inspect all fiberglass joint seams for proper adhesion.
- Inspect all exterior and interior surfaces for proper care and maintenance (e.g. regular wash and wax of exterior siding).
- Inspect all roof moldings, trims, vents, antennas, roof racks, and other attachments for moisture tight seal.

Owners must have all authorized factory repair depots **OBTAIN FACTORY REPAIR AUTHORIZATION PRIOR** to executing any warranty repairs. Any costs associated with transporting the vehicle to the factory or other authorized repair facility is the sole responsibility of the owner.

EXCLUSIONS

The scope of this warranty is expressly limited to only items constructed by Adventurer Manufacturing. Adventurer Manufacturing therefore makes no warranty with respect to component parts constructed or assembled by other manufacturers, including, but not limited to the LPG and electrical appliances, heaters, refrigerators, plumbing fixtures, light fixtures, lights, entrance door, and windows. These component parts may be warranted by their respective manufacturers, and copies of such warranties are included with the camper. This warranty shall not apply to damage caused by abuse, misuse, neglect, alteration, modification, accidents or normal wear and tear. Nor does this warranty apply to parts made from cloth, leather, wood, paint, or chrome which has been affected by airborne fallout, such as chemicals and tree sap, or by road salt, hail, windstorm or other environmental factors. No payment or other, including, but not limited to, towing, telephone, transportation, lodging, travel, gasoline, loss of pay or indirect or consequential damage including, but not limited to, loss of use of the vehicle, inconvenience, damage or injury to person or property, or loss of revenue incurred or sustained by reason of a manufacturer's defect covered by this warranty. Adventurer is not responsible to any purchaser of this recreational vehicle for any undertaking, representation or warranty made by dealers during the course of selling this recreational vehicle, beyond those herein expressed.

As the manufacturer of the camper, which you have purchased, Adventurer Manufacturing cannot know the purpose you have in mind for your truck and camper, nor can Adventurer Manufacturing know the GVWR of your truck. Therefore, Adventurer Manufacturing makes no warranties or representations, express or implied, as to the performance of your truck if the match up of your truck and camper exceeds the GVWR as specified by your truck's manufacturer. Specifically, there is no express or implied warranty of merchantability or of fitness for the match of your truck to any particular camper.

IDENTIFICATION

Adventurer Manufacturing is a Canadian owned company with a reputation for quality and reliability. We build all of our units with Canadian & US conditions in mind. Each unit is identified with the following labels or plates:

- A. RVIA and ANSI labels are affixed to the exterior of each unit, usually near the entrance door. Adventurer Manufacturing meets or exceeds these specifications.
- B. Camper label is attached to the exterior of all truck campers. This label is near the entrance door and shows the model, serial numbers, date of manufacture and camper mass.



A

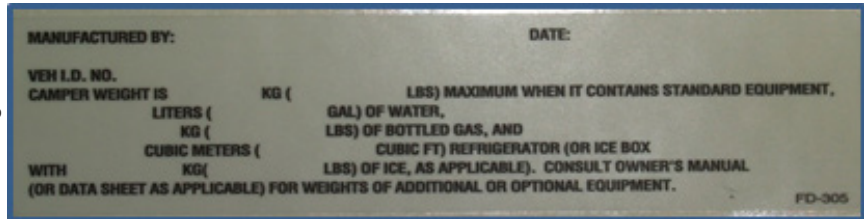

B

CENTER OF GRAVITY “COG”

⚠ WARNING Failure to follow COG loading instructions may change the handling of truck, causing accident, injury and death.

On each Adventurer Truck Camper (left and right) vertical offset is the center of gravity label. The center of gravity must be within the manufacturer’s COG load range of your truck (usually found in your vehicle owner’s manual).
 When packing your camper: Store heavy gear first, keeping it on or near the camper floor. Place heavy objects or items far enough forward to keep the loaded camper’s center of gravity within the area recommended by the manufacturer. Store only light objects on high shelves. Distribute weight to obtain even side-to-side balance of the loaded vehicle.

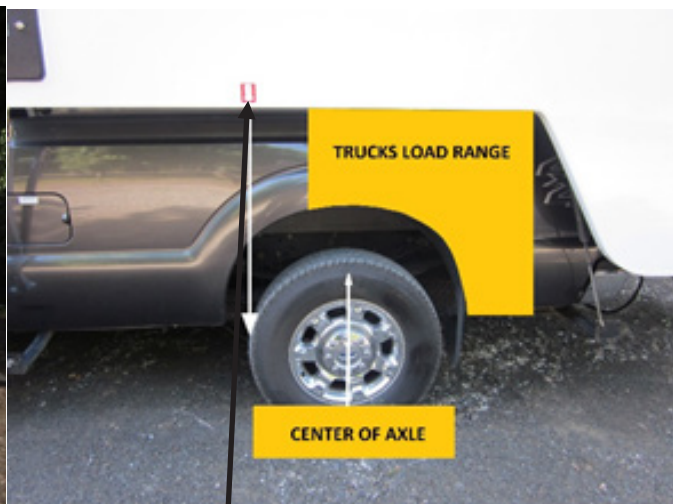

COG load range will vary on every truck and is the owner’s responsibility to make sure their truck and camper are compliant with manufacturer’s recommendations.

COG Label on Camper
(COG= Center of Gravity)

WEIGHT INFORMATION

⚠ WARNING Overloading may cause accident, injury or death.

CAUTION: THIS IS A GUIDE ONLY. Please ensure that your truck is the right size for the camper you have purchased, as this is solely the responsibility of the owner.

The weight of your truck camper is stated on the camper's interior serial decal. This weight includes only the **STANDARD EQUIPMENT**, as listed on the specification decal found on the galley cabinet end in your unit. In addition, this label will also show the dry weight of your camper with all options as completed at the manufacturing facility. Camper weights vary depending on the dry or wet weight, plus options etc.

CAUTION: YOU MUST REMEMBER THAT THE ADDITION OF OPTIONAL EQUIPMENT WILL INCREASE THE WEIGHT OF YOUR CAMPER.

This must be added to the maximum camper weight figure used to select the appropriate truck. When the truck camper is loaded, drive to a scale and weigh the front and the rear axles separately to determine axle loads. The load on an axle must not exceed its gross axle weight rating (GAWR). The total of the axle loads must not exceed the gross vehicle weight rating (GVWR). Weight ratings are given on the vehicle certification label, which is normally located in the glove box or on the left side of the vehicle door post or door edge. If weight ratings are exceeded, move or remove items to bring the weights below ratings.

⚠ WARNING It is your responsibility to ensure weight capacity is not exceeded. Accident, property damage, injury or death may occur.

It is very important that as the owner you properly match your truck and camper to the weights specified by your vehicle manufacturer as said, owners are solely responsible for proper fitting. Truck bed sizes and bed to cab heights vary. Make certain that there is a minimum 1 1/2 in clearance between the truck cab and camper overhead. Make certain that all tie-down points in the truck bed are rated to hold the camper. It is recommended that a 1/2" thick or thicker rubber mat be placed in the truck bed under the camper.

PROPANE SYSTEMS

⚠ DANGER LP gas is flammable and potentially explosive. Always follow proper handling, lighting and ventilation procedures.

The stove, refrigerator, water heater and furnace are all operated with LP gas, which is stored in tanks in the propane compartment of your unit. The gas is fed through a regulator that has been preset to the correct pressure. **CAUTION!: DO NOT CHANGE THIS SETTING.** Gas lines must be checked periodically for possible leakage. See your RV dealer for an annual gas (propane) test. A manufacturer's manual has been provided for each of the

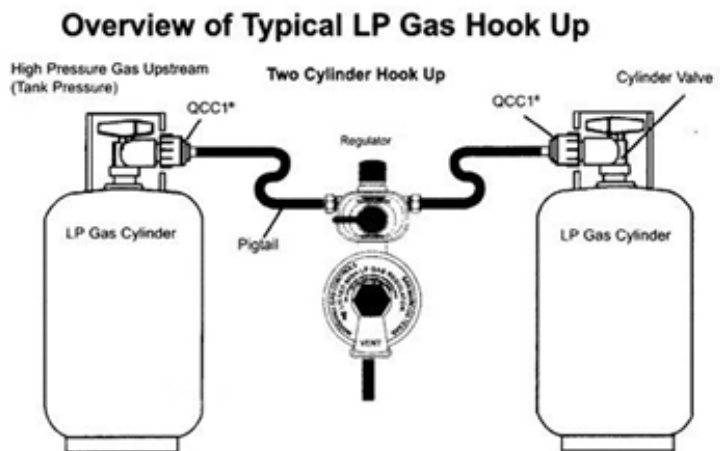

gas appliances furnished within your Owner Supplement Bag. Read each of them carefully and operate the equipment in accordance with the instructions.

LP GAS SAFETY PRECAUTIONS

Historically, LP gas is a safe and reliable fuel. As with any other volatile and flammable material, common sense dictates that LP gas be handled and used with respect and caution. Because LP gas systems are so reliable, they are often taken for granted. Neglect can be very dangerous. If the system is maintained regularly, you can expect almost trouble-free operation.

FILLING LP GAS TANKS

! WARNING Do NOT fill propane containers to more than 80% of capacity. Overfilling can result in uncontrolled gas flow which can cause FIRE and EXPLOSION. A properly filled container holds about 80% of its volume as liquid.

! WARNING Turn off LP main valve and individually turn off gas appliances or electrically disconnect automatic ignition appliances before entering an LP gas bulk plant or motor fuel service station.

NOTICE: Safety standards IN SOME AREAS prohibit operation of an LP gas refrigerator while the motor vehicle is in motion. IF THIS IS THE CASE IN YOUR AREA, ensure that the propane tank valve is in the OFF position.

LIGHTING LP GAS APPLIANCES

Detailed operating information for the LP appliances can be found in your Owner Supplement Bag. **WARNING!:** Please read and follow these instructions.

! DANGER The distinctive ODOR of LP gas indicates a leak.

! DANGER IF YOU SMELL GAS:

1. Extinguish all open flames, pilot lights, lanterns and smoking materials.
2. DO NOT touch electrical switches.
3. Shut off the gas supply at the tank valve(s) or gas supply connection.
4. Open the windows and exit the unit leaving the door open.
5. Stay out of the unit until the odor clears.
6. Have the propane system checked IMMEDIATELY and the cause of the leak corrected BEFORE using the system again.

1. Inspect the entire LP system for leaks or damaged parts before each trip.
2. Do not restrict access to LP tanks (no locks on access doors). In an emergency the propane tank service valve must be easily accessible.
3. Be sure the tanks are securely fastened in their storage compartment whenever they are mounted in the camper.

USING LP GAS SYSTEMS AT LOW TEMPERATURES

Your gas system will function at low temperatures provided the system components are kept at a temperature above the vapor point of the LP gas (-44F).

NOTICE: LP gas systems can freeze up in very cold weather. It is a common misconception that the regulator or the gas itself freezes. It is moisture or water vapor that gets trapped in the system or absorbed by the gas that freezes causing the problem. This ice can build up and partially or totally block gas supply. There are several things you can do to prevent this freeze up:

- Be sure the LP tank is totally moisture-free before it is filled.
- Be sure the tank is not overfilled. This is also a safety consideration.
- Keep the valves on empty tanks tightly closed.
- Have the LP tanks purged by the LP gas service station if freeze up occurs.

FIRE AND SAFETY

LPG LEAK DETECTOR

An installed LP gas leak detector is located near the floor in the camper. The unit contains an alarm that will sound, alerting you to the presence of low levels of potentially dangerous LP gas that may have been released due to a range top/oven burner flame loss, a gas pipe leak or an incorrectly adjusted appliance burner.



! WARNING This propane detector detects the presence of LP gas, it does NOT disconnect the gas supply. The camper interior electrical harness must be connected to a power source for proper operation.

! WARNING Test the operation of this alarm after the recreation vehicle has been in storage, before each trip and at least once per week during use.

! WARNING The test button only tests the alarm circuit, not the sensor. You should use propane or butane gas to test the sensor. Replace the alarm after 5 years.

TESTING: Simply press the Test/Mute switch at any time the alarm is powered. The LED should turn RED and the alarm should sound. Release the switch.

IMPORTANT: If this alarm does not test properly, return it immediately for repair or replacement.

! DANGER NEVER ignore any ALARM. Failure to respond can result in injury or death.

COMBINATION SMOKE & CARBON MONOXIDE DETECTOR

Most fire casualties are caused by inhalation of toxic fumes (smoke from a fire and not by flame). The combination smoke & carbon monoxide detector has separate sensing chambers for smoke and carbon monoxide that work independently of one another. It is battery powered and complies with UL-217, ULC- S531, and CSA 6.19-01. It is located in the living/cooking area of your camper. Please read the Owner's Manual for details on testing and caring for this important safety device.



! WARNING Test the operation of this alarm after the recreation vehicle has been in storage, before each trip and at least once per week during use.

TESTING: To test this Smoke/CO alarm press and hold the Test/Silence button 3-5 seconds until the unit starts to alarm. Turn the device counterclockwise to remove it from the bracket. The detector should never be disabled due to nuisance or false alarm from cooking smoke, a dusty furnace, etc. Ventilate your camper with fresh air and the alarm will shut off.

! WARNING This smoke/CO alarm can not operate without working batteries. Removing the batteries for any reason, or failing to replace the batteries at the end of their service life, removes your protection.

Replace the batteries once a year or immediately when the low battery "beep" signal sounds once a minute. The detector uses two standard "AA" batteries, usually available at any retail store that sells batteries. Test the operation of the detector after replacing the batteries. If the detector fails to operate with new batteries, replace it with a new unit.

FIRE EXTINGUISHER

The fire extinguisher in your camper is located near the main entrance door. Read the operating instructions that are printed on the extinguisher. You and your family should be familiar with fire extinguisher operation. **WARNING!** Your fire extinguisher should be replaced immediately after use or discharge.



ELECTRICAL SYSTEM

Most electrical systems in your truck camper including the lighting, operate on 12-volts. 12-volt power is supplied from the battery of the truck through a charge line in your 7-pin plug (if so equipped), or from an auxiliary battery (1 or 2 depending on model), which can be installed in the camper through your dealer at delivery. In addition, your unit is equipped with an Intertek 110-volt 30-amp power supply cord, which can be plugged into any available outlet. The plug will display correct and incorrect wiring on the back of the plug using a red and green LED bulb, for more information on the cord's operations see the manufacturers owners guide.



This current goes into the 45-amp converter, which changes it to 12-volt before feeding it into the circuits. This system automatically switches to batteries when disconnected from external 110-volt, or vice versa. Auxiliary batteries are charged through the alternator of the vehicle when running and/or through a built-in charger in the 45-amp converter when connected to 110V power. Your batteries can also receive a charge from an on-board generator if you have this option.

⚠ WARNING	Do Not install fuses with amperage ratings greater than specified, as this may cause a fire.
------------------	--

ELECTRICAL CONNECTION TO TRUCK

The truck's 7-Pin electrical connection can be installed by your dealer according to your truck's wiring system, if not already equipped from the factory. With the wiring and connectors hooked-up, your truck can supply 12-volt DC power to charge your camper battery and provide power for the 12-volt power needs while the truck is operating. See the listing below for truck side 12-volt connector wire colors, wire gauge and function:

NOTICE: DO NOT use less than 10-gauge wire size for charge lines. Also, DO NOT attach to smaller gauge wires.

Your dealer should ensure that the wiring between the vehicle and your unit is adequate for the demand system.



GROUND FAULT INTERRUPTER

Bathroom and patio (where equipped) 120-volt electrical outlets are protected by a Ground Fault Interrupter (GFI). This device is provided in compliance with ANSI A119.2/NFPA 501C and CSA requirements and is intended to protect you against the hazards of line to ground electric faults and electrical leakage shocks possible when using electrical appliances in the bathroom or damp areas.



SYSTEMS MONITOR PANEL

The systems monitor panel incorporates controls and instrumentation concerning the electrical and fluid systems. Some models also have switches for optional automatic water heaters and generators.

WATER PUMP CONTROL SWITCH

This rocker switch controls the on-demand water pump. The water pump is pressure sensitive and starts (with the switch ON) when a faucet is opened, causing pressure in the line to drop. When the faucet is closed, pressure builds in the line and the pump stops. **NOTICE:** This switch should be in the off position when traveling.

MONITOR PANEL-LEVELS INDICATORS SWITCH

When depressing the monitor switch, indicator lights for the black (waste/toilet), gray (sink/shower), freshwater tank and battery charger will illuminate, indicating the existing condition of each component.

NOTICE: Erroneous indications when checking water levels can be caused by:

Water with a low mineral content level is measured by a very low electrical signal traveling through the liquid. Some water which is low in mineral content may not conduct the signal properly. Check the panel reading when the freshwater tank is filled.

Material trapped on the sides of the holding tanks may give a full reading when the tank is actually empty. Use of the optional "Black Tank Flush" or a spray wand inserted into the toilet to wash out the tank following dumping should help prevent this condition.

When testing approximate battery condition, first turn all lights, fans and other 12-volt equipment OFF. If the battery is being charged the charge light will illuminate when the monitor switch is depressed. If only a weak light is illuminated, discontinue use of all 12volt equipment until the battery can be recharged.

WATER SYSTEM

The dual water systems, in Your Adventurer Truck Camper, supply water from either the unit's storage tank (potable water) or directly from the city water hookup.

FRESH WATER TANK

Your Adventurer Truck Camper has an on-demand water system for the (potable) freshwater tank. There is a separate connection for the city water hookup on these units (read below). With the on-demand system, the ON/OFF Water Pump Control Switch must be in the ON position and the unit powered in order for the electrically operated pump to draw water from the unit's storage tank. Turn the switch ON while



camping. Turn the switch OFF to shut down the system while traveling, while hooked up to city water or when the unit is not in use. Filling the potable water tank can be done by means of a hose or a bucket. Periodic draining of the tank and flushing it with a tablespoon of baking soda will keep it fresh and clean.

CITY WATER HOOKUP

To use the city water system, simply attach a clean freshwater hose (not a garden hose) from a service faucet to the city water connection. When the faucet is turned on, water will be supplied to the unit, including the water heater, and will pressurize your lines much the same as at home. **NOTICE:** Because of varying system PSI, you should always use a pressure regulator to eliminate the possibility of damaging the water lines in your unit. These are available at most any RV supply store or dealer (40 PSI is recommended and safe).



HOT WATER TANK

If your Adventurer Truck Camper is supplied with a hot water system, carefully read the manufacturer's operating instructions (included with your owner's manual – in your Owner Supplement Bag). Following these directions will ensure an adequate supply of hot water at all times, wherever you are. The correction of a failure, though rare indeed, is not a job for the do-it-yourselfer. There are hundreds of authorized service centers across North America. Your Dealer is probably one of them.

WASTEWATER SYSTEM

Your Adventurer Truck Camper may be equipped with one or more wastewater holding tanks. One is known as the "gray water tank", where waste from the shower, kitchen and bath sinks are stored; the second is the "black water tank" where your toilet waste or sewage is stored. Both have their own drainage valves, but empty through the same discharge outlet.

To drain, open the cap and connect the outlet to a dumping station with a sewer hose (not supplied with the camper) and open the large valve (3") for the toilet tank (black tank) and let it drain and leave open at this point. Then open the smaller valve to drain (1½"), the grey water tank, by dumping in this order the "grey soapy water" will help clean your dump line and sewer hose. If you have the optional "black tank flush" on your camper, the next step is to connect a fresh water hose to this connection, turn on the water

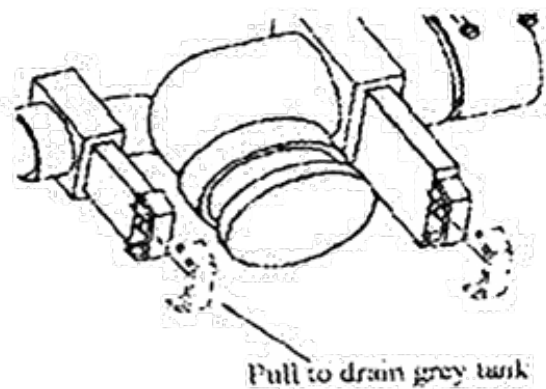
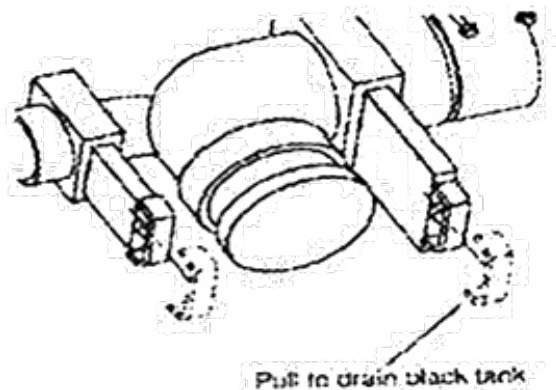

and this feature will spray fresh water inside of your black tank through a jet system further rinsing your black tank for a cleaner, fresher tank.

NOTICE: Make certain your black tank valve is open before turning on the water or you will damage your black tank, floor and/or flood your unit! Turn off the water to your black tank flush (if equipped with this option), close both of your dump valves, disconnect your sewer hose and store it away and be sure to reinstall your dump line cap for travel.

Note: Add about a gallon of clean water and a good deodorant chemical through your toilet to keep your black tank clean and fresh at all times. This is a good practice even when storing your unit.

When connected to a sewer in a park or campground, the toilet holding tank valve should remain closed until the tank is almost full. Then drain and recharge black water tank as above. This method will avoid undesirable buildup in the tank, causing reduced capacity and/or costly repairs.

LOADING & UNLOADING YOUR CAMPER

There are presently two types of jacks used on Adventurer Truck Campers. They are New Generation Happi-Jac (manual) and New Generation Happi-Jac (electric) with wireless remote control.



Electric Screw Jack



Wireless Remote



Manual Screw Jack

CAUTION When unloading your camper, be sure all tie-downs and electrical connections are disconnected.

WARNING Use extreme caution when unloading your camper in a strong wind. Load and unload your camper on level ground, NEVER an obvious grade.

DANGER Keep children and animals away from the area when raising or lowering the camper. Avoid putting any part of your body under the camper during the procedure.

DUALY BRACKETS

SWING-OUT BRACKETS (OPTIONAL)

To load or unload campers on dual rear wheel trucks, swing-out brackets will need to be installed on the front jacks to clear the dually/fender. To operate, follow the steps below:

1. Lift jack from the travel notch locked position and swing outward from the camper body.
2. Position jack so when camper jack is lowered, the notch and raised tab engage to prevent rotation.
3. Repeat the process for the other front mounted jack.
4. Follow the standard camper loading and removal procedures below.

MANUAL JACK OPERATING INSTRUCTIONS

- Remove dust cap and pull release locking lever to the "unlocked" (Down Position) at top of jack before cranking. Be sure to reset locking lever to the "locked" (UP Position)
CAUTION! DO NOT leave jacks in the unlocked position for an extended period of time.
- When jacks are not being cranked to avoid accidental extension/retraction.
- Insert crank handle firmly into the crank socket of the jack. Starting at the front, begin cranking.
- Extend each jack no more than 4 - 6" at a time at all four corners starting with the front jacks, keeping the camper level or the front slightly higher at all times. Repeat this process until the camper is clear of the truck body bed by approximately 4 to 6". (If there are two people working the jacks, one on each side, it is a very easy task). The use of a cordless drill is a nice accessory to speed up this process. **WARNING! Never raise the back of your camper higher than the front.**
- See "Continuation for all Jack Versions" below to continue.

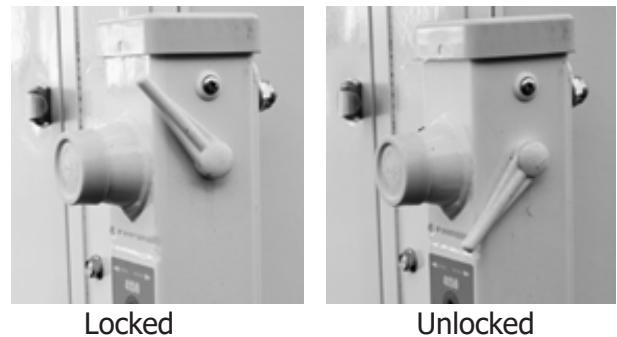

OPERATING REMOTE CONTROL ELECTRIC JACKS

NOTICE: Do not over-extend or over-retract jacks. Each jack has built in stops. If excessive force is applied against the stops, damage to the jacks may occur. This is usually noted by a ratcheting sound. Electric jacks need 12-volt automotive battery power to operate. The camper battery must be charged and in good condition. If the battery is too low to operate the jacks, charge the battery before using jacks. If the camper is on the truck, starting the truck's engine will supply power to the jacks as long as the 12-volt electrical cord is connected. If no power is available, use the manual override operation noted above.

NOTICE: Do not use the electric jacks to raise or lower the camper using only 120-volt power. The converter's charger can be damaged if the jacks are operated with 120-volt power through the 12-volt converter without an automotive battery or with a low battery. *A well charged battery in good condition is required.*

CAUTION! Before operating the remote-controlled electric camper jacks, be sure to read and understand the operating instructions that were provided with your camper pertaining to their safe operation.

The jacks are operated with a handheld remote control. To activate, locate and press the two center "all jacks" buttons simultaneously, then press the two top "Accessory" buttons simultaneously to activate the remote, while the same actions in reverse order turn off the remote. A light on the face of the remote will illuminate when activated and dealuminate when inactive. The remote is on a time delay, that will automatically shut off after 10 minutes of inactivity. This feature helps save your remote batteries and adds additional security for your camper. After use, store the remote in a secure place away from access by children.

ELECTRIC JACK OPERATING INSTRUCTIONS

- Locate your wireless remote control. Activate per manufacturer's instructions.
- Press the appropriate buttons on remote control to lift the camper until it is clear of the truck body bed by approximately 4 to 6". **NOTICE: One button can run all jacks at once and each jack has its own button to run each jack individually. Make sure all jacks are touching the ground before using the "all jacks" button to raise your camper. Failure to do this can result in damage to your camper.**
- See "Continuation for all Jack Versions" below to continue.

CONTINUATION FOR ALL JACK VERSIONS

- Slowly back the truck under the camper making sure to clear the wheel wells and camper jacks. **NOTICE: If you have a dually truck, make certain you have swing-out jack brackets on the front jacks to clear your dual wheels and fenders.**
- Continue backing up until the truck is within a foot of the fully loaded position. Stop and connect the 12-volt power cord to the "7-pin" 12-volt receptacle on the truck (this may need to be installed by your dealer if your truck doesn't already have one). Before continuing check to see that the distance between the truck's taillights and the rear of the camper has at least 1" separation. If not, add an appropriate wood shim in the front of the truck bed as a spacer before continuing. (This is rarely needed but a good practice for a new camper install).
- Continue backing under the camper until the bumpers/camper guides, mounted on the front corners of the camper, are approximately 1" from the front of the truck bed.
- Slowly retract both rear jacks then front jacks, lowering the camper and maintaining the most upright and level position as possible. For manual jacks, retract each by hand until the camper is resting fully on the truck bed. For electric jacks all jacks can be retracted or extended at the same time.
- While lowering **never** retract the front jacks to a position where the rear of the camper is more elevated than the front, instead always keep the rear of the camper below or even with the front of the camper while lowering. Continue to retract jacks until the camper lays evenly in the bed of the truck.
- Raise the jack base pads to within 2" of full retraction for travel or to jack manufacturer's directions. **NOTICE: Failure to fully retract jack legs as described can cause damage, extended jacks can catch on curbs, etc. while driving.**

- If equipped with swing-out brackets (for dually trucks), disengage the swing out bracket on the front jacks and move the brackets to the inward position for travel.
- Secure the camper to the truck with a set of high quality tie-downs. Hook one end to the camper tie-down under the wing or jack bracket of the camper and the other end to your camper tie-down bracket installed on your truck. It is RECOMMENDED that all tie-downs be spring loaded. (We recommend Torklift Tie-Downs and Fast Guns as our tie-down of choice but there are many other acceptable options).
- Install all four, 2-front and 2-rear, tie downs as per the manufacturer's directions
- Stow remote control or jack crank handle for future use.

UNLOADING

To unload reverse above procedure.

- When camper bed is clear (front & back) of the truck, slowly drive truck forward, being careful not to hit the jacks.
- Our campers are designed to be used off the truck. To lower the camper to a suitable height for use off the truck, reverse the above procedure bringing the camper down to 2" from the bottom of each jack, and then you can level your camper.

NOTICE: If you are going to leave the camper on your truck disconnect your tie downs before leveling your camper with the jacks, failure to do this can result in damage to your truck and/or camper.

TIP: Use plywood pads under each jack to keep from sinking in soft ground or hot asphalt!

TOWING AND HITCH SYSTEMS

A hitch system should be installed on your truck by QUALIFIED PERSONNEL ONLY.

 WARNING	Towing will change the handling and braking characteristics of your truck and camper.
--	---

LOADING CARGO

 WARNING	Overloading may cause accident, injury or death.
--	--

CAUTION! When loading your camper, store heavy gear first, and place down low. Distribute weight as evenly as possible from side to side. Remember overloading or uneven loading can create a serious safety hazard and may shorten the service life of chassis components. Do not load upper cabinets with heavy items. Secure and brace stored items so they won't move during travel, thereby shifting the load in the camper. Carry only as much water as needed for travel use and whenever possible, empty the wastewater holding tanks before traveling.

CARRYING CAPACITY

The number and size of storage components and liquid tank capacities are maximized for value

and convenience. If the camper operator fills all liquid tanks to capacity and fills all storage compartments and cupboards to maximum volume, the truck may exceed its GVWR. The **operator** is responsible for analyzing the conditions under which the truck and camper will be used for each trip. After you have determined how much weight you can safely carry and selected those items to make up that weight, make a list and keep it for future reference.

 WARNING	It is your responsibility to ensure weight capacity is not exceeded. Accident, property damage, injury or death may occur.
--	--

CAMPER FEATURES

VENTS

All exterior vents provide air circulation for the unit. **WARNING!** Do not block these vents as equipment damage, or hazards to occupants may result. **NOTICE:** Ceiling vents need to be retracted and in the closed position while moving the camper.

LIGHTING

Your camper is equipped with exterior lights to conform to state and federal regulations. **NOTICE:** Do not alter the lights or reflecting markers. Replace any burned out bulbs or damaged parts as soon as possible.

BATHROOM

The toilet is designed to flush with a minimal amount of water and still provide for proper disposal and odor control. Toilet chemicals are available at most RV retail locations. Review the booklet supplied in the Owner Supplement Bag with your toilet for proper operation and maintenance.

DINETTE BED

All Adventurer Truck Campers come equipped with a dinette that will convert into an additional sleeping area. Your dealer will provide instruction on the proper conversion of this area.

LADDER AND ROOF RACK

Your Adventurer Truck Camper may come equipped with a ladder. It may be used to access the roof. The roof is walkable. There may be an optional roof rack installed on the rear of your camper's roof. The roof rack is designed to secure light bulky items. **NOTICE:** Do not store any cargo on the roof of your camper unless you have a roof rack installed.

 WARNING	Use extreme caution when using the ladder and accessing the roof of your camper. Fall, serious injury or death may occur.
--	---

EMERGENCY ESCAPE

Your Adventurer Truck Camper comes equipped with emergency escape windows. One is located behind/above the dinette area and another in the cab-over sleeping area. The Heki skylight can also serve as an emergency escape hatch. Please see Owner Supplement Bag for operation instructions and familiarize yourself with their operation in advance, in case of emergency.

STORAGE

Interior storage areas may be found in a number of places in your camper: overhead compartments, wall closets, P.J. boxes, under the dinette seats, and galley cabinets for your convenience.

APPLIANCES

For proper appliance lighting, operation and maintenance, consult the appropriate appliance manufacturers reading materials contained in the Owner Supplement Bag.

LIGHTING LP GAS APPLIANCES

Air trapped in the gas lines may delay the initial lighting of any appliance. It could take several seconds or longer for the gas to reach the appliance. The first time the furnace or oven is lit; paints and oils used in the manufacturing process may generate some smoke and fumes. If this occurs, open doors and windows to air out the camper. If this happens it should burn off quickly and not be an issue going forward.

NOTICE: Always follow the appliance manufacturer's lighting and operating instructions, found in the Owner Supplement Bag.

MICROWAVE OVEN

Your Adventurer Truck Camper may come equipped with an optional microwave oven.

CAUTION! This item should never be operated when empty. Please consult the manufacturer's owner's manual in the Owner Supplement Bag for proper operating instructions.

REFRIGERATOR

The refrigerator operates on 120-volt AC power and LP gas. The operating instructions supplied in the Owner Supplement Bag will help you with detailed information from the manufacturer.

The recreational vehicle LP type refrigerator operates on the "absorption" principle and therefore **MUST BE** reasonably level for maximum efficiency. When your camper is stationary, it should be leveled for comfortable living. If you can occupy the camper comfortably, the refrigerator unit should perform well. If the refrigerator unit is not "close to level", it may not

function properly, and your food will not be adequately cooled.

When the camper is in motion, the continuous movement will not affect operation. The operating instructions are printed inside near the controls and may be found in the manufacturer's instruction manual, in your Owner Supplement Bag.

Operating Tips

- Operate the refrigerator on 120-volts for 8 to 12 hours (overnight) before you leave on a trip. This will allow the refrigerator and freezer to get cold and even have some ice ready.
- Pre-cool food and drinks before putting them into the refrigerator.
- For off-truck use, some refrigerator models must have 12-volt battery hooked up to power the electronic controls. Refer to the supplied appliance manuals for proper operating instructions found in the Owner Supplement Bag.

WATER HEATER

Before lighting, open the water heater relief valve and/or hot water valve and run until water flows without the presence of air. Do not operate the water heater until it is filled with water.

NOTICE: Not doing this can result in damage to your hot water heater. Refer to manufacturer's instructions found in the Owner Supplement Bag for more information.

RANGE / OVEN

Gas burners and the oven use Liquid Propane (LP) gas for fuel. All campers are equipped with a spark igniter for lighting the top burners. The 3 burner range used in some of our models is equipped with one high output burner when additional heat is required.

 WARNING	Cooking appliances require fresh air for safe operation.
--	--

Before use:

- Open overhead vent or turn on exhaust fan
- Open window or door

 WARNING	It is not safe to use cooking appliances for comfort heating. Do NOT use open flames to warm the living area.
--	---

SLIDE OUT

Your Adventurer Truck Camper may be equipped with an electric slide out to provide more interior room in your camper.

OPERATING THE ELECTRIC SLIDE OUT

The switch for the slide out is located just inside the entry door close to the floor for your convenience.



Slide when in



Slide when out

NOTICE: Always make sure the camper is in a reasonably level position before putting slide out. Damage can occur.

- Locate the slide **on/off switch** right next to the slide operation switch (on some models)
- Switch to the on position.
- Hold slide operation button in the out position until the slide is fully out.
- To bring the slide back in, hold the button in the in position until the slide is fully closed.
- In both cases when extending or retracting the slide do not continue to hold the switch after the slide has reached its desired position. This may cause damage to the slide mechanism.

SLIDE-OUT MANUAL OPERATION

If the slide fails to operate because of a slide motor malfunction, dead battery, etc. please do the following:

- Locate the slide on/off switch right next to the slide operation switch (see above).
- Switch to off position to enable manual mode
- Remove the plastic cap at rear of camper on the same side as the slide room.
- Install slide crank onto socket of motor turning crank until slide is all the way in. In some cases, you may have to reach under the slide to disengage the slide brake lever.
- Return slide on/off switch to the on position.

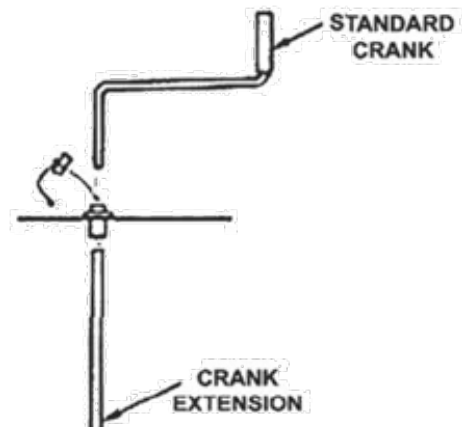

CAUTION! This procedure should only be used in an emergency.

Additional information with photos is on-line at: www.AMLRV.com (under manuals).

MAINTENANCE

MAINTAINING EXTERIOR AND INTERIOR FINISHES

EXTERIOR

The high gloss fiberglass exterior of your truck camper will withstand sun exposure while maintaining its appearance. Periodic washing and waxing can enhance the life of the exterior. Any high quality RV or automotive exterior wax will work fine in maintaining your camper exterior. **NOTICE:** Do not use harsh abrasives or strong solvents to clean the surface, as this may result in discoloration or damage.

INTERIOR

The interior of your truck camper is finished with high quality natural woods and paneling. Regular cleaning with warm, soapy water and an application of furniture polish will preserve its beauty. **NOTICE:** Do not use self-adhesive hooks or fixtures, masking or scotch tape on the paneling. These may damage the finish and leave unsightly marks when removed. A surprising range of items can be supported by common straight pins. When removed, the tiny hole is almost invisible.

DRAPES AND UPHOLSTERY

Window draperies, valances, bedspread and upholstery should be treated in a like manner to those in your home. Remember that they will be subjected to more sunlight than is usually normal, so extra care and attention should be given. Never dry-clean your cushion covers, as this will result in the vinyl backing disintegrating. Use upholstery cleaner, which is sprayed on and vacuumed off when dry. The draperies should not be dry-cleaned either. They should be washed in warm water only, as hot water may damage the plastic glides. **NOTICE:** Do not dry these items in your dryer as this may also cause damage.

NOTE: CSA & RVIA code regulations require fabric blinds to be a certain distance away from flame sources i.e. gas cook tops. Therefore, a mini-blind in the galley area may be substituted instead of a fabric shade to meet these codes.

FLOORS AND CARPETING

Vinyl flooring is non-wax and only requires mopping, no waxing is required. Vacuum carpeting regularly and clean with a good quality carpet cleaner.

POWER RANGE HOOD

Clean the filter in hot water with detergent and wipe down the surface with mild soapy water. Use a soft cloth to dry.

REFRIGERATOR

Clean interior with mild soapy water after each trip. When defrosting, be sure the drip tray is in place under the finned evaporator. The water will be carried through the drain tube to the outside of camper. Check the drain tube periodically to assure it's not plugged. Drain tube

should always be routed through the exterior vent so draining does not occur inside of the camper as this can cause damage to your camper.

SHOWER CARE

Household cleaners are recommended. **NOTICE:** Never use harsh detergents, abrasive cleaners or steel wool to clean the fiberglass surface.

DRAINS

If a sink fails to drain, use a standard wire drain cleaner to clear the clog. **NOTICE:** Do not use strong chemicals.

WINTERIZATION

Winter in most parts of North America can be harsh and take its toll on all types of vehicles and equipment. The rigors of winter should not discourage you from enjoying the RV life-style. Thoughtful planning and preparation for the winter season can help eliminate equipment failures and breakdowns and can extend the life of your RV and its systems.

Your dealer can advise you concerning specific winterization procedures and products for your climate area or the areas through which you will be traveling. Your dealer may also provide winterization service for all appliances and systems in your camper. A 'physically fit' RV will stay in shape much better through the winter.

If you choose not to travel during the winter and will be storing your unit during periods of freezing temperatures, follow a thorough winter storage procedure.

WINTERIZING YOUR CAMPER

NOTICE: Draining the water system alone will not provide adequate cold weather protection, if the camper is to be unheated during freezing temperatures. Consult your dealer for the best winterizing procedure for your climate. Your dealer can winterize your camper for you or can supply you with one of the special antifreezes that are safe and approved for use in RV water systems. Follow the instructions furnished with the antifreeze.

! WARNING Do NOT use automotive or windshield washer antifreeze in the camper water system. These could be harmful if swallowed.

FRESH WATER SYSTEM

- Open hot and cold water faucets.
- Open the low point drain valves on **HOT** and **COLD** water pipes.
- Drain the water heater by opening the drain plug at the bottom of the heater and open the safety valve. Open the hot water faucets.

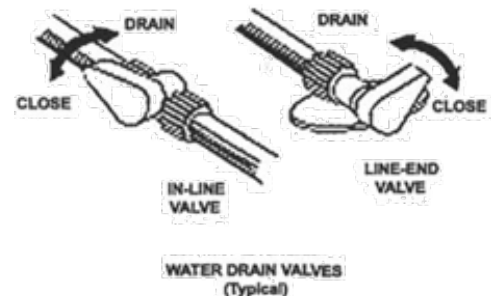



Pressure Temperature Relief Valve

Drain Plug

- Open all cold-water faucets and depress the flush pedal or pull the flush levers on the toilet. When each faucet has been opened, drained, and closed, close the water line drain valves, and freshwater tank drain valve.
- Drain the shower head by opening the valve. Let all water drain out the tub spout. Leave the valve open.
- Be sure ALL water from ALL plumbing fixtures has been drained.
- If your unit is equipped with a water heater bypass valve, close the valves to by-pass heater tank.
- Make sure fresh tank drain valve is closed. Pour one gallon of RV approved non-toxic anti-freeze into the freshwater tank.
- Turn the water pump master switch to ON and run pump through galley faucet for 20 seconds.
- Turn the water pump master switch to off.
- Drain approximately one cup of anti-freeze from freshwater tank drain, cold low point drain, and hot low point drain.
- Insert the hose from the winterizing valve into a container of RV approved non-toxic anti-freeze.
- Turn the valve to have the pump pick up from hose.
- Turn the water pump master switch ON.
- Open each cold-water faucet, run the water pump and let about a cup of antifreeze solution flow continuously through each faucet. Close each cold water faucet.
- Open each hot water faucet and repeat the above.
- Depress the flush pedal (or otherwise operate the flush mechanism) on the toilet until the antifreeze solution flows continuously. Release flush mechanism.
- Pour a cup of antifreeze solution down each drain.
- After the water systems are completely filled with antifreeze, remove the water purifier filter cartridge if equipped.
- **Install all protective caps:** water tank fill, city water inlet, waste tank drain outlet.

Winterization of the freshwater system is complete.

WASTEWATER SYSTEM

- Drain the wastewater system.
- Apply graphite lubricant to the knife valve actuator rod.

PREPARING YOUR UNIT FOR STORAGE

The following checklists will help you perform the steps necessary to prepare your Adventurer Truck Camper for storage. Use the checklist that applies to the storage conditions you anticipate. These checklists will not include every detail required, and you may want to expand them to suit your needs.

SHORT-TERM STORAGE ABOVE FREEZING (LESS THAN 60 DAYS)

- Camper should be level as possible front to rear and side to side.
- Check the charge in the battery and be sure it has a full charge on maintenance free batteries. On batteries that requires maintenance (battery inspection caps) remove caps and test with a hydrometer. Hydrometer reading should be 1.255. Add clean drinking quality water when necessary to maintain electrolyte level, and charge to a reading of 1.255.
- Remove battery cables. Clean terminals, top and sides of batteries and battery boxes. Leave the battery disconnected.
- Drain holding tanks, toilet, and living area water systems. Turn off water pump and water heater master switches.
- Turn off LP gas at tank valve.
- Turn off refrigerator and furnace.
- Turn all range and oven burner valves and pilot valves (if equipped) off.
- Remove all perishables from refrigerator and kitchen cabinets. Block refrigerator door open to reduce odor buildup. An open box or tray of baking soda in the refrigerator will help absorb odors.
- Open closet doors, dressers and cabinets so air can circulate through them.
- Close all roof vents. Be sure vent fan and range hood fan switches are off.
- Cover exterior vents (water heater, furnace, range hood and refrigerator) to prevent insects from getting in. **NOTICE: Be sure to remove all covering material before re-using appliances or vents.**
- Cap or close holding tank drain, city water inlet and freshwater fill spout.
- Turn off all radios, TVs and interior and exterior lights.
- Close drapes and curtains.
- Check the unit weekly.

LONG-TERM STORAGE ABOVE FREEZING

- Perform steps as listed under Short-Term Storage.
- Operate air conditioner periodically to lubricate compressor seals.
- Disconnect battery and check charge (Specific Gravity) with a hydrometer every 30 days. Recharge as necessary.
- If you expect to store the unit for an extended period, you may want to support the weight of the unit on appropriate blocks or jack stands as a safety precaution.
- Remove high grass or weed growth under or around the unit.

GENERAL CAMPER WINTER STORAGE CHECKLIST

- Perform steps as listed under Long-term Storage.
- Close and cover all vents to prevent entry of snow or small animals and insects.
- Check the sealant around all roof, body seams and windows. Reseal if necessary.
- Lubricate all locks and hinges with light oil or graphite.
- Support the weight of the unit on appropriate blocks or jack stands as outlined above.
- During extended storage, charge and remove the battery. Store it in a cool, dry place, and check the charge and water level every 30 days.
- Mattresses and cushions should be propped up to allow air flow, and prevent moisture damage or mold growth.
- Remove all perishables and canned goods.
- Clean refrigerator and prop door open to allow circulation of air.
- Remove, clean and replace air conditioner filters.
- Cover the air conditioner shroud(s).
- Mask the windows on the inside to reduce curtain, drape and carpet fading.
- Thoroughly clean the interior of the unit, including carpets, counter tops, toilet, tub & shower and galley.
- Remove batteries in clocks or other battery-powered devices.
- Remove snow accumulations as often as possible.

REACTIVATING THE UNIT AFTER STORAGE

- If the unit was properly and carefully prepared for storage, taking it out of storage will not be difficult. You should not experience any problems except minor surprises such as animal nests underneath or minor body scratches, and of course dirt accumulations on the outside. The following procedure checklist assumes that you stored the RV with care. If you didn't, and extensive freeze damage or other serious deterioration has occurred, please consult your dealer for advice.
- Thoroughly inspect the outside of the camper. Look for animal nests in appliance vents, wheel wells or in other out-of-the way places.
- Open all doors and compartments. Check for animal or insect intrusion, water damage or other deterioration.
- Remove all appliance and ceiling vents and air conditioner coverings. Be sure all furnace, water heater and refrigerator openings are clear and free of debris or insect nests, webs, etc.
- Check charge level in battery. Refill and recharge as necessary. Reinstall battery if necessary. Be sure cable ends and terminals are clean and free of corrosion.
- If unit has been stored on blocks or jacks, remove these.
- Open vents and windows for ventilation.
- Be sure all 12-volt and 110-volt circuit breakers are off.
- Check the operation of taillights, turn signals, backup lights, clearance lights, license plate light and emergency flashers.
- **Drain, flush and sanitize the freshwater system.**
 1. Drain residual antifreeze from freshwater tank.
 2. Fill freshwater tank with fresh water.
 3. Turn bypass valve to BYPASS position.

4. Turn water pump ON.
5. Open water faucet farthest from water tank until clear water appears. Shut off faucet. Repeat at all other faucets, showerhead and toilet.
6. Turn bypass valve to NORMAL position.
7. Reinstall hot water heater plug (if removed)
8. Open hot water faucet until clear water appears.

Repeat steps 2 through 8 as necessary to assure clear water is flowing through all parts of the system. **The freshwater system is now ready for use.**

- Drain the holding tanks. Inspect the drain hose for leaks. Replace if necessary.
- Operate all faucets and fixtures in the freshwater system. Check for leaks at all joints and fittings. Repair if necessary.
- Inspect the LP gas system. Remove the regulator cover, check for damage. Inspect all pipes and fittings in the system. If the propane tanks show signs of rust or corrosion, sand and paint it as necessary.
- Turn on 12-volt circuit breaker and inspect fuses. Operate all 12-volt lights and accessories.
- Install new batteries in battery-operated devices (smoke detector, carbon monoxide etc).
- Check monitor panel operation.
- Open and operate vents and vent fans, including the range hood fan.
- Operate each gas appliance. Observe all burner/pilot flames for proper color and size. In any case, have the LP gas regulator adjusted for proper pressure.
- Inspect the 110-volt electrical system and power cord, converter, all outlets and any exposed wiring. If defects are found, refer service to your dealer.
- Turn on 110-volt circuit breakers.
- Operate 110-volt appliances and air conditioners. Be sure to uncover air conditioner shroud(s).
- Inspect and clean the interior.
- Check the sealant around all roof, body seams and windows. Reseal if necessary.
- Lubricate all exterior locks, hinges, and latches.
- Wash and wax the exterior. Inspect the body for scratches or other damages.

Your truck camper should now be ready for a new traveling season. If you choose, your dealer can double-check your preparation and correct any defects or make any necessary adjustments.

TRAVEL TIPS

Before leaving your campsite area, it would be wise for you to have a card made out with the following items to be used as a check list.

- Power Cable disconnected & stowed
- Sewer Line disconnected & stowed
- Water Line disconnected & stowed
- Step up
- Hatches and vents closed
- Refrigerator locked
- TV secured and antenna down

- Doors and drawers shut, and curtains tied
- Jacks are up
- Tie-downs are attached and secured to truck
- Mirrors aligned

SOME USEFUL EQUIPMENT TO TAKE ALONG

- Toolbox and an assortment of small tools, test light and fuses
- Plastic bucket for carrying water
- Blocks for leveling your recreational vehicle
- RV water hose (high pressure) and 'Y' connection in case of 2 units on one water outlet
- Water pressure regulator
- Sewer hose
- 100 ft., 3 wire electrical cord with at least 30 amp capacity
- Spirit level
- Short handled shovel
- First Aid Kit
- Fire Extinguisher
- Flashlight
- Road Emergency Flares

Thank you once again for purchasing an Adventurer Truck Camper. Drive safely and have a safe trip.

Happy Camping!

TROUBLESHOOTING

FAQ

Q. *Can I drive my truck with the slide out?*

A. No.

Q. *Can I sleep on the over cab bunk, when the camper is on the ground?*

A. Yes, be sure front of camper is higher than the rear.

Q. *I just emptied my black tank, but the Monitor panel shows half full?*

A. Material trapped on the sides of the holding tanks may give a false reading. Use of the optional "black tank flush" system or a spray wand to flush out the black tank following dumping should help prevent this condition.

Q. *My unit is pre-wired for various add-ons. How do I find where the wires are located?*

A. Please contact Adventurer Manufacturing at amlrv@amlrv.com

Q. *How do I empty my sewage (black) tank?*

A. Both grey and black tanks have their own drainage valves, but empty through the same outlet. To drain, the black tank, connect the outlet with a sewer hose to a dumping station and open the large valve for the toilet tank and let it drain. Then open the smaller valve to

drain the grey water tank. Close valves. Add clean water and a good deodorant chemical to keep tanks clean and fresh at all times. When connected to a sewer in an RV park, the toilet holding tank valve should remain closed until the tank is almost full. Then drain and recharge black water tank as above. This method will avoid undesirable buildup in the tank.

Q. *My propane tank is full and connected properly, but my appliances are not lighting.*

A. ALP uses QCC-1 connections, at the cylinder valve end. The nipple has a patented Flow Limiting Device that shuts off gas flow if a leak occurs between the regulator and the appliance burner valve. It activates each time you open the cylinder valve, so be sure the appliance is turned OFF before you open the valve and open it slowly. If the appliance is not turned OFF when you open the valve, or if you open the propane tank valve too quickly, the Flow Limiting Device will not be able to reset and will restrict gas flow to the appliances. The QCC-1 connector is also heat sensitive, shutting off the flow of gas if it is exposed to temperatures between 240 & 300 degrees F.

Q *My Water heater is leaking at the High Pressure/Temperature (PT) relief valve.*

A Occasionally, you may experience "weeping" of the PT valve, caused by the normal expansion of water as it is heated. The tank is designed with an internal air gap at the top to reduce this weeping. In time, the heating and expansion of the water will absorb this air.

NOTES

NOTES

NOTES

 **ADVENTURER**

 **Adventurer**
Manufacturing

(Adventurer Manufacturing)

Adventurer LP

3303 W. Washington Ave., Yakima WA 98903

Phone: 509-895-7064

Fax: 509-895-7068

Email: amlrv@amlrv.com

www.amlrv.com

www.adventurercampers.com